

B 12TH FLOOR TERRACE (PARCEL 3)
SCALE: 3/8" = 1' - 0"

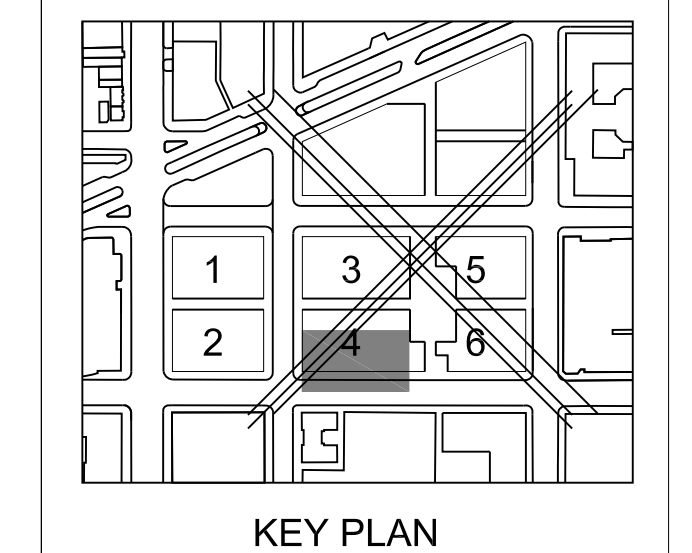

KEY PLAN
SBA PROJECT NO: 32-009

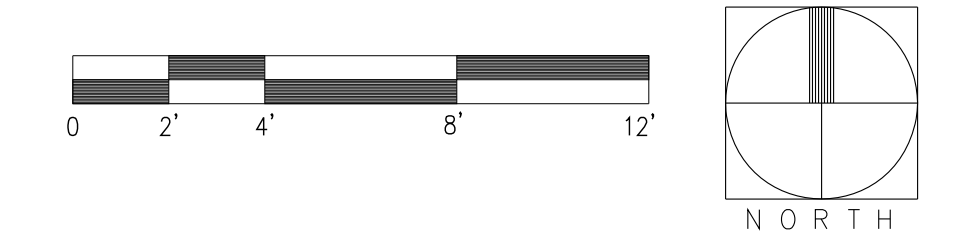
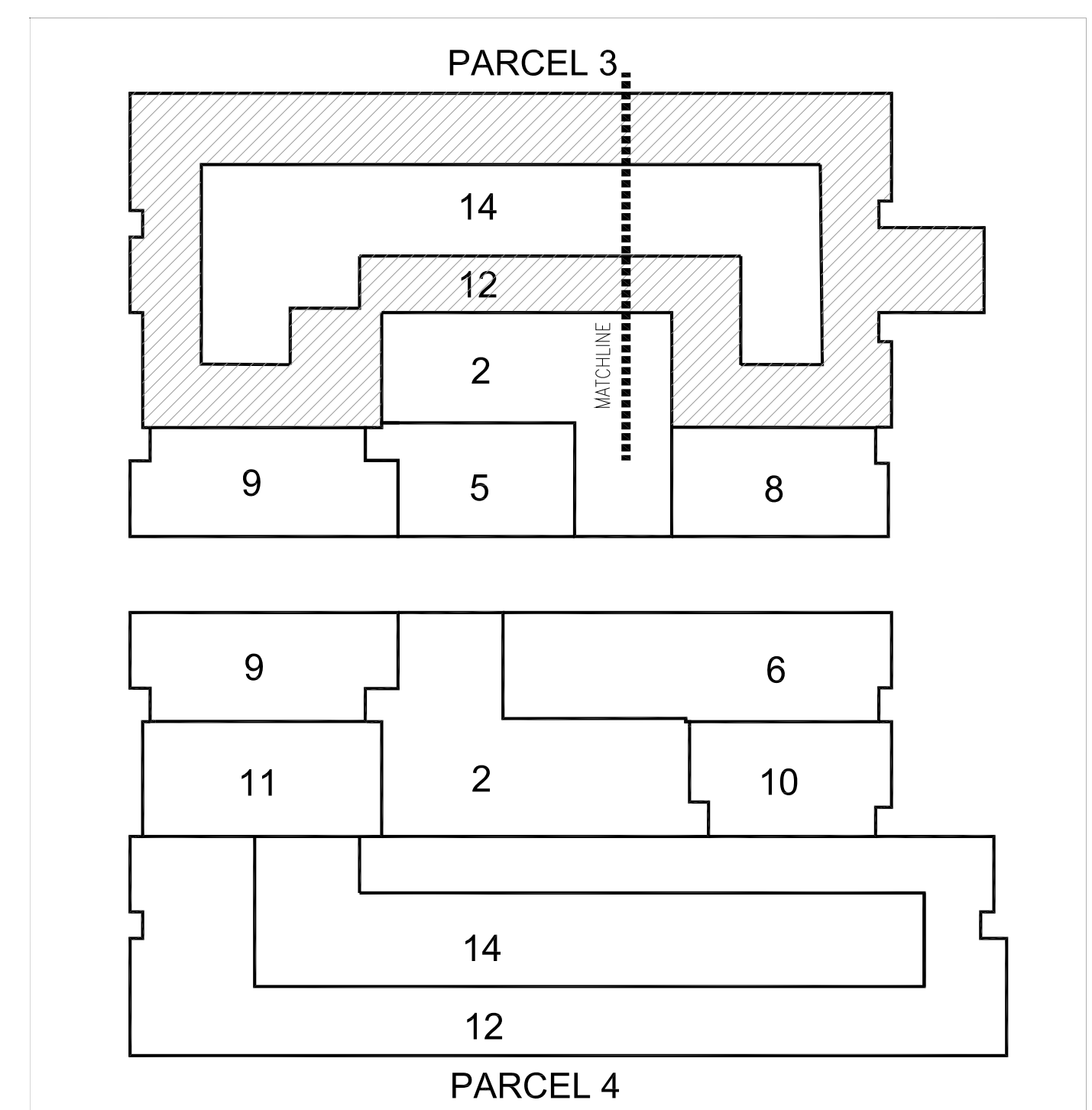

LEVEL 12 ROOF TERRACE (PARCEL 3) - SITE + MATERIAL PLAN
SCALE: 1/4" = 1'-0"

ISSUED: 03/31/11 FOR CONSTRUCTION

REVISIONS:
1. 09/15/11 BULLEIN #2

2. 10/26/12 BULLEIN #24

COPYRIGHT, © 2008 SBA, PC

L1-12.3-1.11

PROGRESS DATE: ##### PROGRESS SET

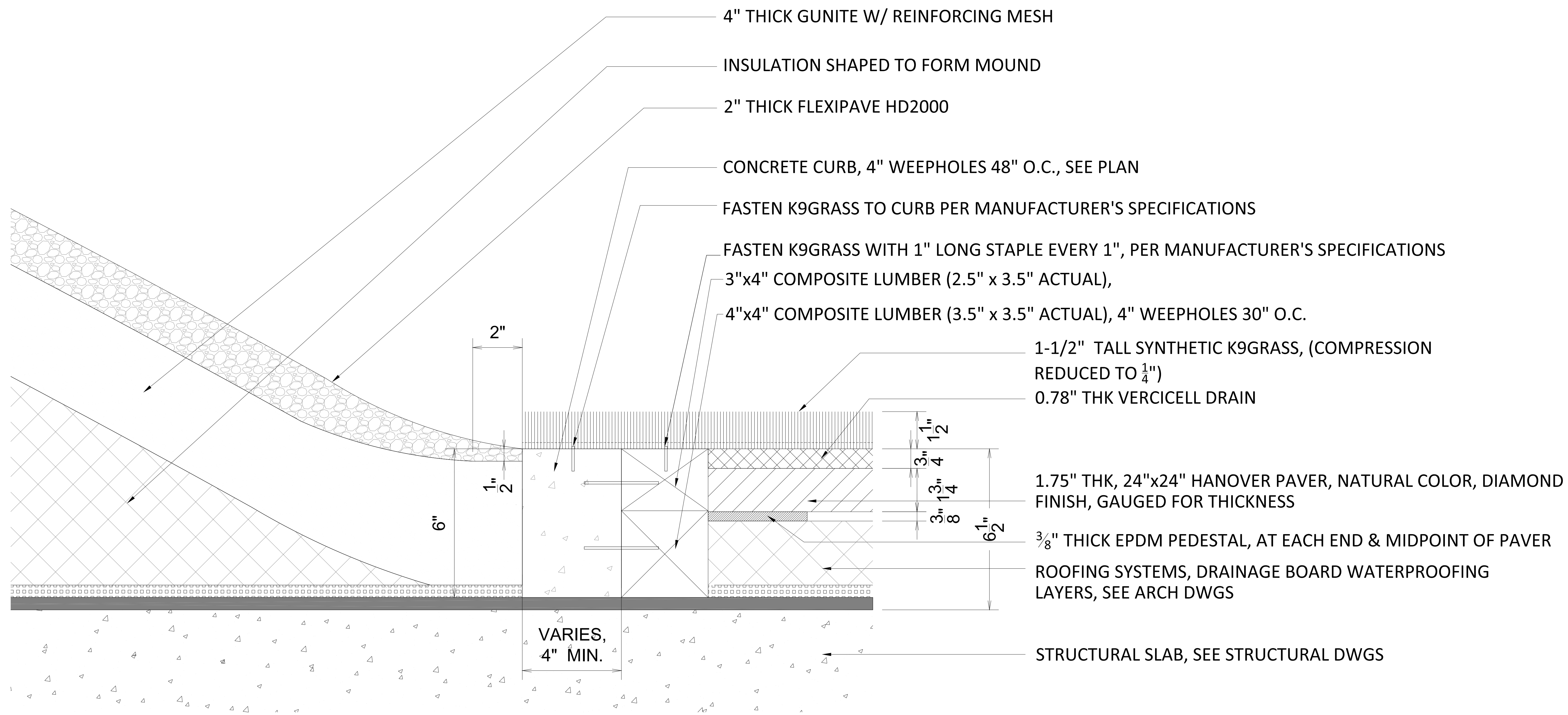

A MOUND DETAIL- NO WEEP HOLE
SCALE: 1-1/2" = 1'-0"

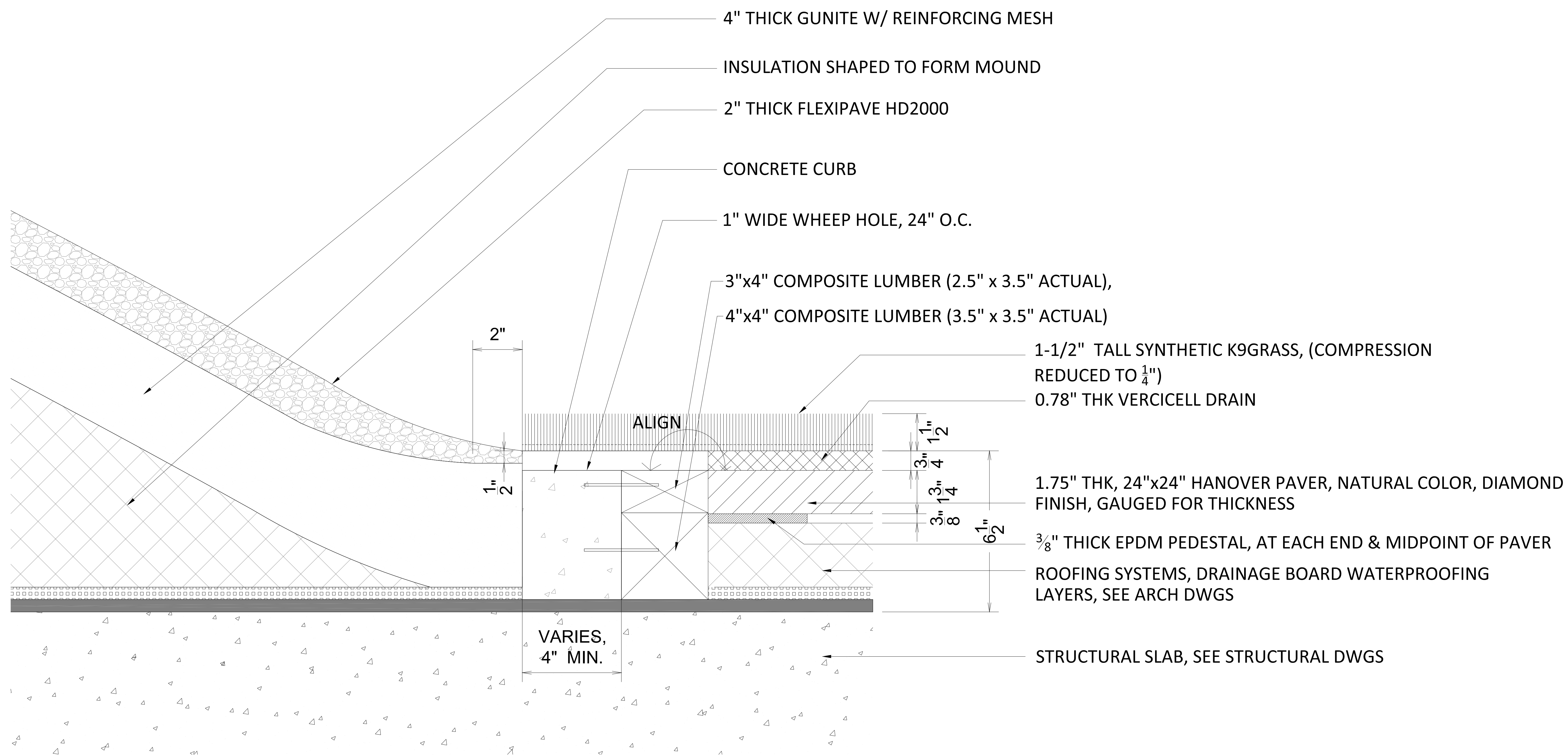

B MOUND DETAIL- WEEP HOLE AT TOP
SCALE: 1-1/2" = 1'-0"

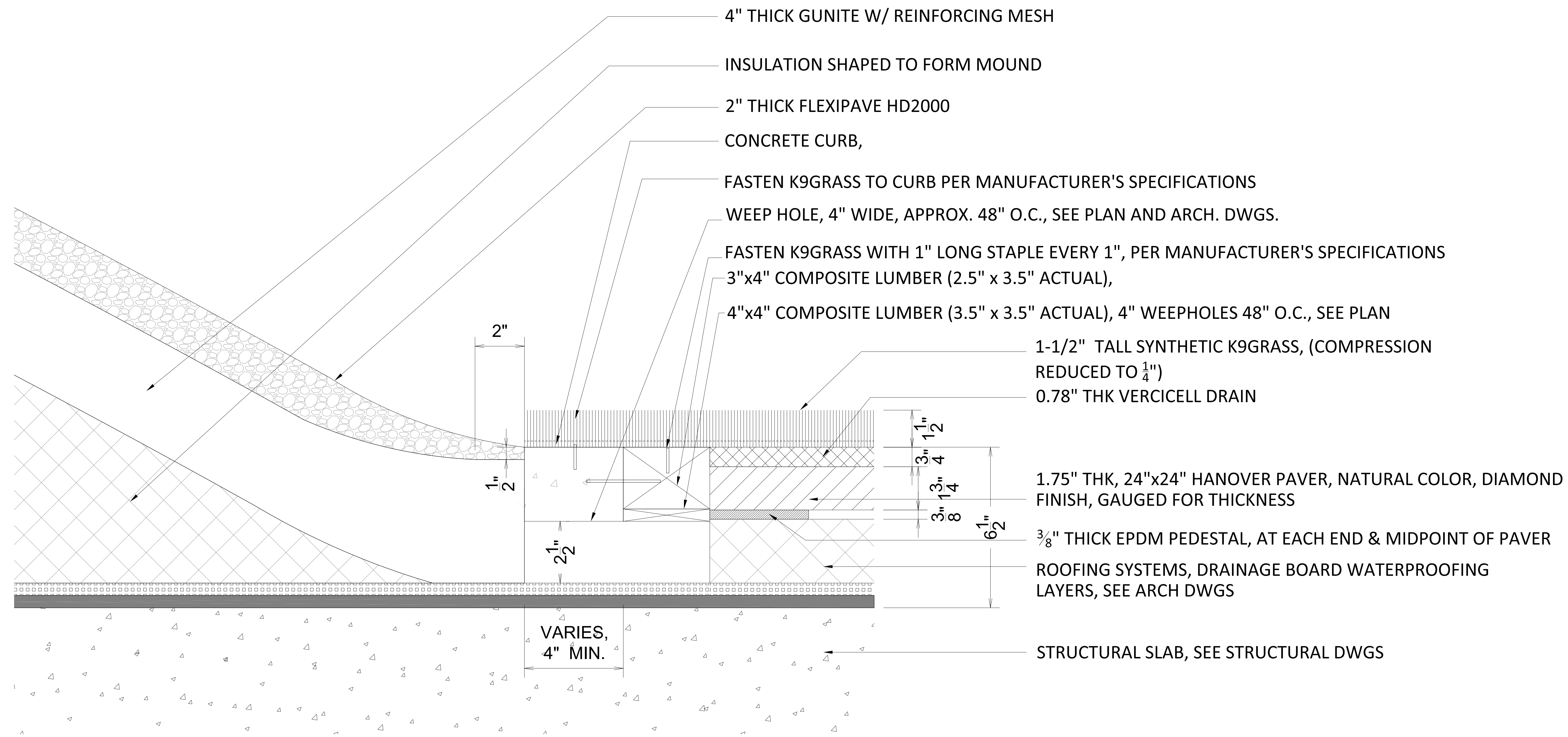

B MOUND DETAIL- WEEP HOLE AT BOTTOM
SCALE: 1-1/2" = 1'-0"

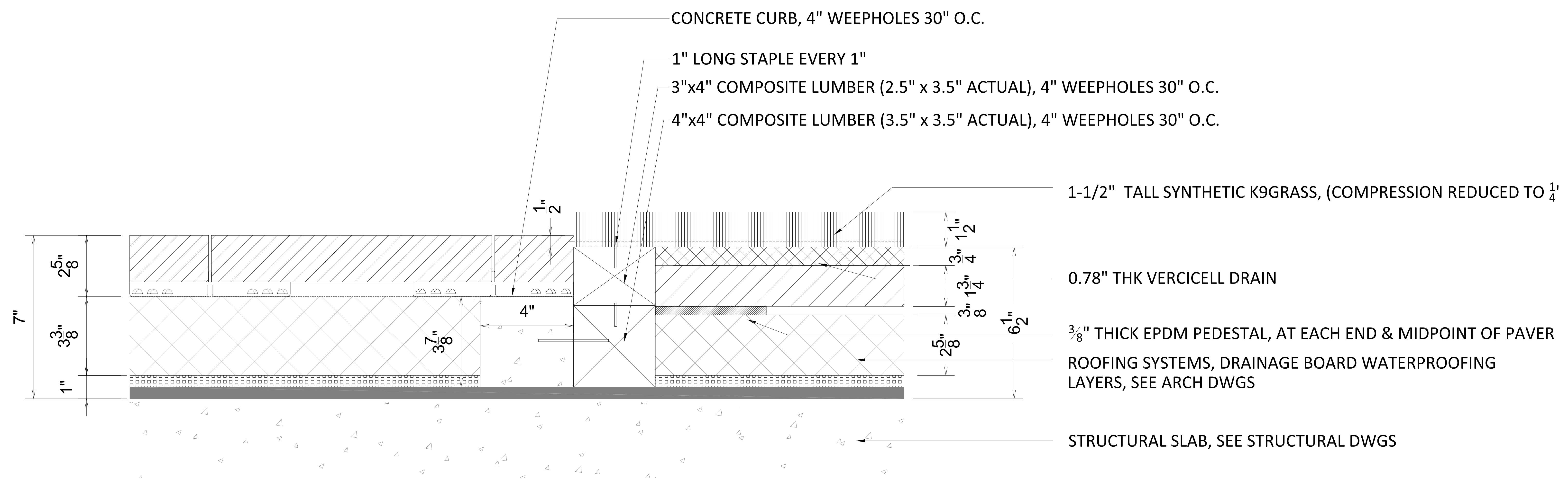

A TURF TO PAVER TRANSITION
SCALE: 1-1/2" = 1'-0"